

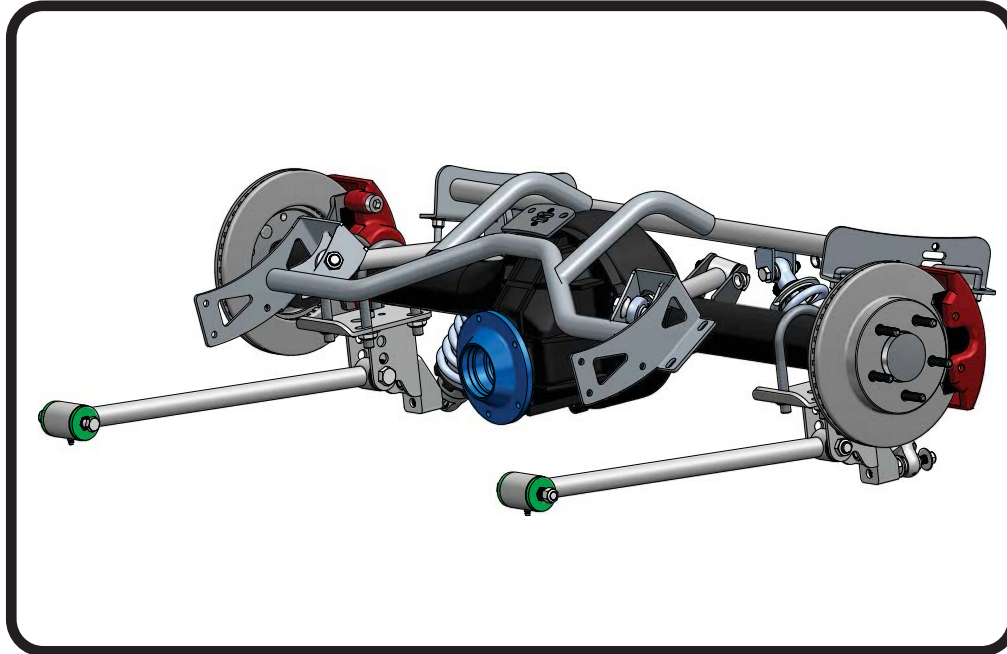

Part # 12087199 -1965-1970 Mustang Rear Bolt-in 4 Link

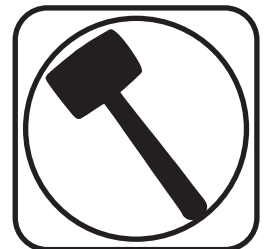

Recommended Tools

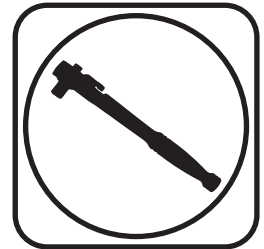

1965-1970 Mustang Rear Bolt-in 4 Link Installation Instructions

Table of contents

| | |
|-------------|---|
| Page 2..... | Included components |
| Page 3..... | Hardware List and Getting Started |
| Page 4..... | Cradle Installation |
| Page 5..... | Lower Axle Mount & Lower Bar Installation |
| Page 6..... | Setting Pinion Angle |
| Page 7..... | Upper Bar Axle Tab Installation |
| Page 8..... | Installing Axle Tabs |
| Page 9..... | Installing ShockWaves/CoilOvers |

NOTE: If your car is equipped with a differential that has the axle tubes swedged to 2 1/4", you will need (4) 99566009 u-bolts. See page 3.





Major ComponentsIn the box

| Item # | Part # | Description | QTY |
|---|----------|---|-----|
| 1 | 90002198 | Upper Cradle | 1 |
| 2 | 90001444 | Lower Axle Mount | 2 |
| 3 | 90002843 | Lower Bar Assembly - 21 3/4" center to center | 2 |
| 4 | 70013767 | Front Lower R-Joint Spacer | 4 |
| 5 | 90002844 | Upper Bar - 11 3/4" center to center | 2 |
| 6 | 70013364 | RH R-Joint Threaded Housing End (installed in upper bars) | 2 |
| 7 | 70011897 | Upper Bar Tab - Tall | 4 |
| 8 | 70012018 | Upper Bar Tab - Short | 2 |
| 9 | 90001624 | Aluminum Lower Shock Mount | 2 |
| 10 | 70002825 | Lower Shock Stud | 2 |
| 11 | 70013334 | R-Joint Spacers | 12 |
| 12 | 90002285 | Square U-Bolts | 7 |
| 13 | 99566001 | Axle U-Bolts | 4 |
| 14 | 99752004 | 3/4"-16 Jam Nut (installed on upper bar Heim) | 2 |
| | 90002067 | Lower Shock Spacers | 4 |
| | 70010694 | Bar Tab Setting Jig | 2 |
| R-Joint Components - (Installed in bar ends) | | | |
| | 70013279 | Retaining Ring | 8 |
| | 70013280 | Wavo Wave Spring | 8 |
| | 70013275 | R-Joint Center Ball | 8 |
| | 70013276 | R-Joint Composite Center Ball Cage | 8 |

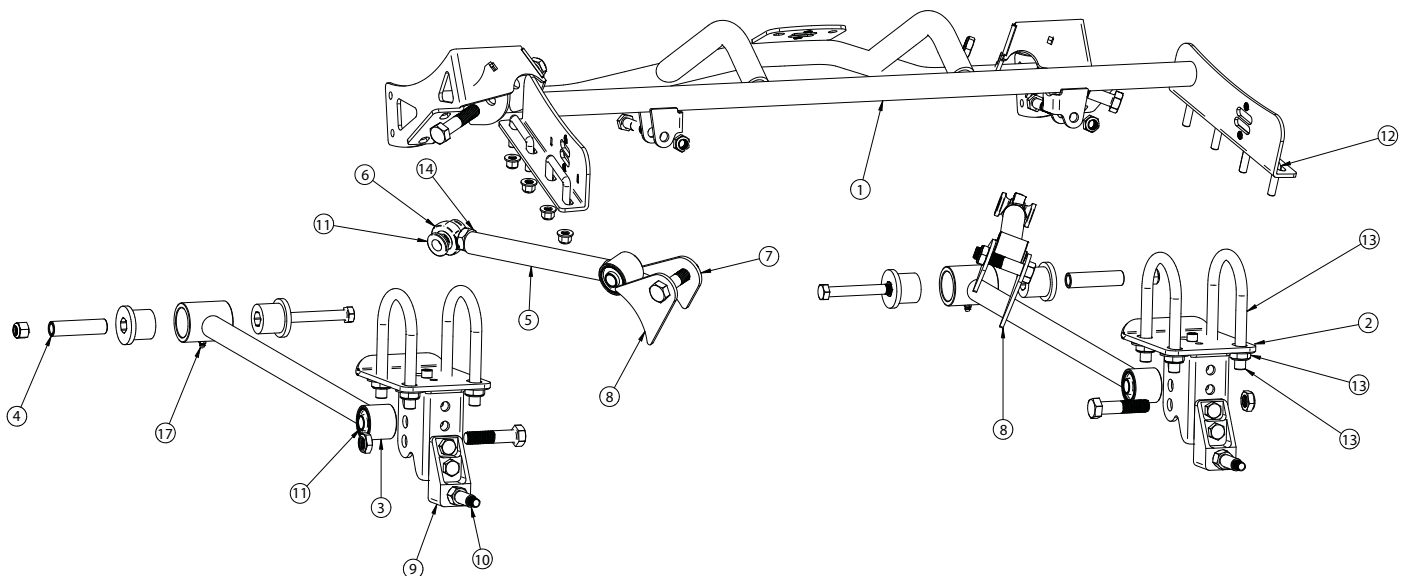



Hardware ListIn the box (Kit# 99010054)

| QTY | Part Number | Description | QTY | Part Number | Description |
|----------------------------------|-------------|------------------------------|-----------------------------------|-------------|---------------------------|
| 4-Link Bars to Mounts | | | U-bolts | | |
| 6 | 99621003 | 5/8" x 2 3/4" Gr. 8 Bolt | 8 | 99566003 | 9/16" SAE Flat Washer |
| 6 | 99622006 | 5/8" SAE Nylok Jam Nut | 8 | 99566002 | 9/16"-18 Hex Nut |
| Cradle to Car | | | Front Lower bar to Chassis | | |
| 14 | 99372002 | 3/8-16" Nylok Nut | 2 | 99501029 | 1/2"-20 x 6 1/2" Hex Bolt |
| 14 | 99373003 | 3/8" SAE Flat washer | 2 | 99501017 | 1/2"-20 x 4 1/2" Hex Bolt |
| 6 | 99373007 | 3/8"-16 Thread Forming Bolts | 2 | 99502002 | 1/2"-20 Nylok Nut |
| Shock Mount to Axle Mount | | | Bar Setting Jig | | |
| 2 | 99501007 | 1/2"-20 x 1 1/4" Hex Bolt | 2 | 99371001 | 3/8"-16 x 3/4" Hex Bolt |
| 2 | 99501009 | 1/2"-20 x 1 3/4" Hex Bolt | 2 | 99372004 | 3/8"-16 Hex Nut |
| 4 | 99502002 | 1/2"-20 Nylok Nut | Shock Stud | | |
| Shock to Cradle | | | 2 | 99432002 | 7/16"-20 Nylok Nut |
| 2 | 99501010 | 1/2"-20 x 2 1/4" Hex Bolt | 2 | 99433002 | 7/16" SAE flat Washer |
| 2 | 99502003 | 1/2"-20 Thin Nylok Jam Nut | 2 | 99623004 | 5/8" SAE Flat Washer |

R-JOINT SPACER INSTALLATION

Install the Spacers by inserting the SMALL side of the SPACER into the Center Pivot Ball. Push them in until they bottom out and stop.

LOWER FRONT R-JOINT

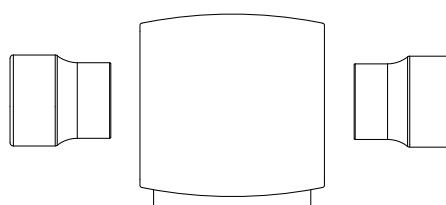

ALL OTHER R-JOINTS

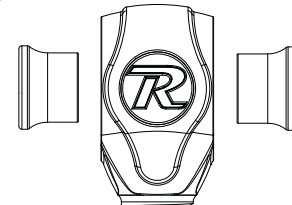

New R-Joints will be quite stiff (75-90 in/lbs breakaway torque) until they "break in" after a few miles of use. After the break in period they will move much more freely. Because the composite bearing race contains self lubricating ingredients, no additional lubrication is needed or desired. Any additional lubrication will only serve to attract more dirt and debris to the R-Joint and actually shorten its life.



SWEDGED AXLE TUBES! - IF YOUR CAR EQUIPPED WITH A DIFFERENTIAL THAT HAS THE ENDS OF THE AXLE TUBES SWEDGED TO 2 1/4", YOU WILL NEED DIFFERENT U-BOLTS. YOU WILL NEED (4) OF RIDETECH PART # 99566009.

Getting Started.....

Congratulations on your purchase of the Ridetech Rear 4-link System. This system has been designed to give your Mustang excellent handling along with a lifetime of enjoyment. Some of the key features of this system: Tune ability, Replaces the Leaf Springs, this allows the 4-Link to locate the rearend and the CoilOvers/ShockWaves to support the car.

Note: These system is designed for use with the Ridetech Shockwaves or CoilOvers. **The factory shocks and springs will not fit this setup.**

1. Raise the vehicle to a safe and comfortable working height. Use jack stands to support the vehicle with the suspension hanging freely.
2. Support the axle and remove the leaf springs, shocks and tail pipes. Refer to the factory service manual for proper disassemble procedures. You might have to detach the fuel line from the frame rails.



Cradle Installation

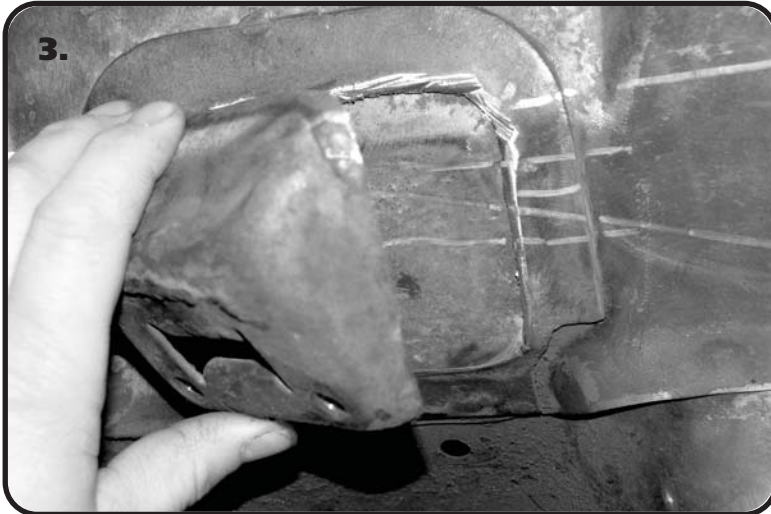

3. Remove the Factory Pinion Snubber and Mount from the car. We use a cut off wheel to remove the mount. Notice that we left the mounting lip of the mount attached to the car. This provides another layer of metal for the Front Tab of the Upper Cradle to attach too.

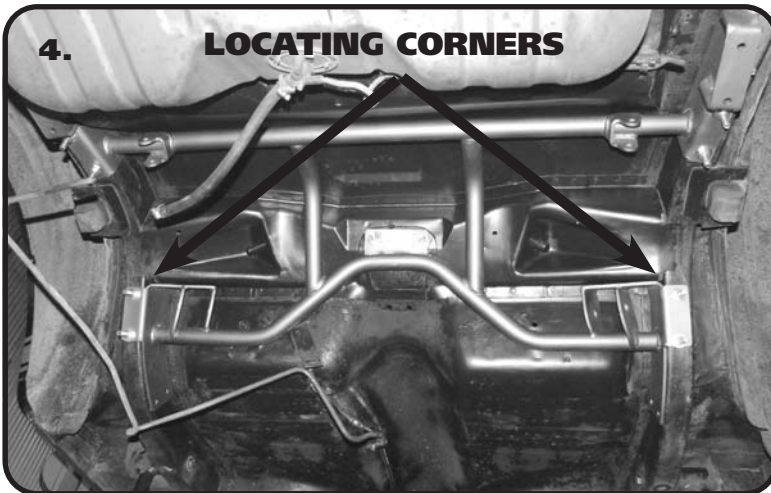

4. Install the cradle into the car. The rear corners of the Upper Bar Mounts locate into the front corner of the factory shock sheet metal mount. The Cradle is held in by (7) 3/8" Square U-bolts. Use the Cradle as a locator for drilling the holes. Drill the holes using a 7/16" drill bit. Drill The front 3 holes on each side with a 5/16" drill bit.

Note: The OEM fuel line will need to be detached from the frame rails until the Cradle is installed.



5. You will notice that the holes are drilled in pairs. Each pair will receive a Square U-bolt. To insert the Square U-bolts into the holes it may be necessary to lower the Cradle to install them. The U-bolts are installed by inserting one end into one of the drilled holes, using the other end as a handle, feed it through the frame until the inserted end will drop down through the remaining hole. Do this for all (7) U-bolts. Install the Cradle into position. Install (1) 3/8" Flat washer and (1) 3/8" Nylok nut onto each stud sticking through the cradle. Do not tighten them until all Washers and Nuts are installed. Install the 3/8" Thread Forming bolts into the 5/16" holes.



Lower Axle Mount & Lower Bar Installation

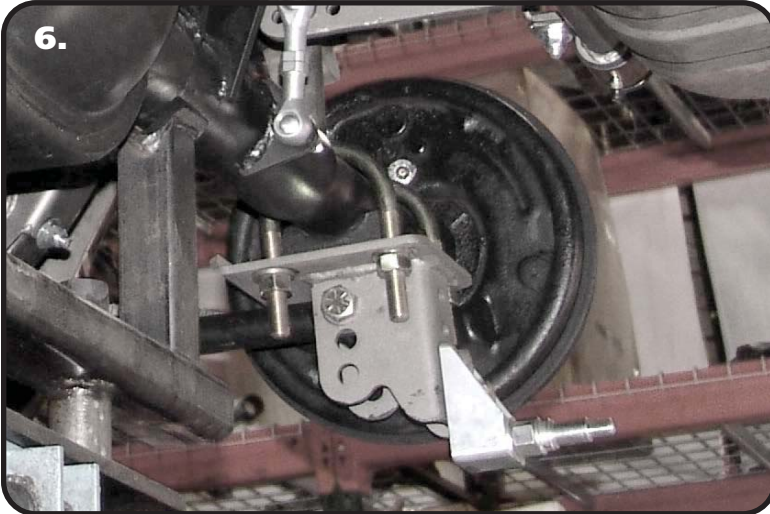

6. Install the Lower Axle Mount onto the Axle using the supplied U-Bolts. Run the nuts down to hold the mount in place, but **DO NOT** tighten yet.

NOTE: If your car is equipped with a differential that has the axle tubes swedged to 2 1/4", you will need (4) 99566009 u-bolts.

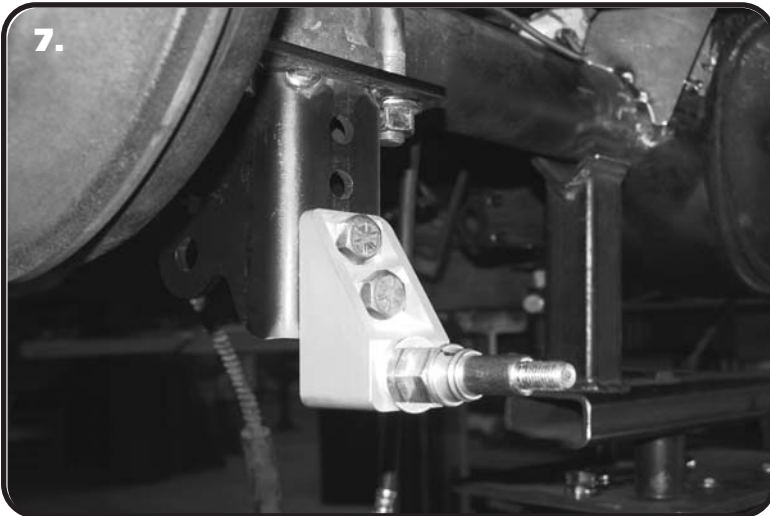

7. Attach the Lower Shock Mount to the Axle Mount using (1) 1/2"-20 x 1 1/4", (1) 1/2"-20 x 1 3/4" Hex Bolts, and (2) 1/2"-20 Nylok Nuts on each mount. The Shock Mount is installed in the **BOTTOM 2** holes of the Axle Mount. Install a Shock Stud and 5/8" washer in each Shock Mount. Tighten the mounting hardware and the Shock Stud.



8. Install the Lower Bars. The Front Lower uses the **WIDE**(70013767) R-Joint Spacers inserted into each side of the R-Joint. The Axle end of the bar gets a **NARROW**(70013334) R-Joint Spacer inserted into each side of the R-Joint. The bar is attached to the Axle Mount in the **TOP HOLE** using (1) 5/8" x 2 3/4" Hex Bolt, and (1) 5/8" Thin Nylok Jam Nut. The front of the Lower Bar is attached with 1/2"x 6" Hex Bolt(64-67) or 1/2"x 4 1/2"Hex Bolt(68-70), and (1) 1/2" Nylok Nut.



Setting Pinion Angle

READ PAGES 6-8 ON SETTING PINION ANGLES, UPPER BAR TAB JIG INSTALLATION, & SETTING RIDE HEIGHT.

How do you set the pinion angle? On a single-piece shaft you want to set it up where a line drawn through the center of the engine crankshaft or output shaft of the transmission and a line drawn through the center of the pinion are parallel to each other but not the same line.

Your transmission angle should be around 3 degrees down in the rear. If it is more or less than 3 degrees, you might want to consider changing it. Too little angle on the transmission reduces the amount of oil getting to the rear bushing. Too much transmission angle will increase the working angles of the u-joints which will increase the wear. With the transmission at 3 degrees down in the rear, you will want to set the pinion 3 degrees up in the front.

A simple way to do this is to place a digital angle finder or dial level on the front face of the lower engine pulley or harmonic balancer. This will give you a reading that is 90 degrees to the crank or output shaft unless you have real problems with your balancer. At the other end, you can place the same level or angle finder against the front face of the pinion yoke that is also at 90 degrees to the centerline. If you rotate the yoke up or down so both angles match, you have perfect alignment.

Road testing will tell you if you have it right. If you accelerate and you get or increase a vibration, then the pinion yoke is too HIGH. Rotate it downward in small increments of a degree or two until the problem goes away. If you get or increase a vibration when decelerating, then the pinion yoke is too LOW. Rotate it upward to correct it.

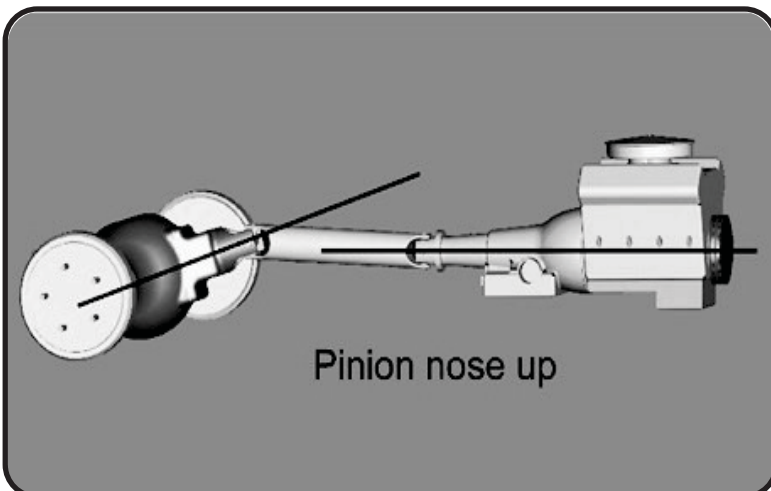
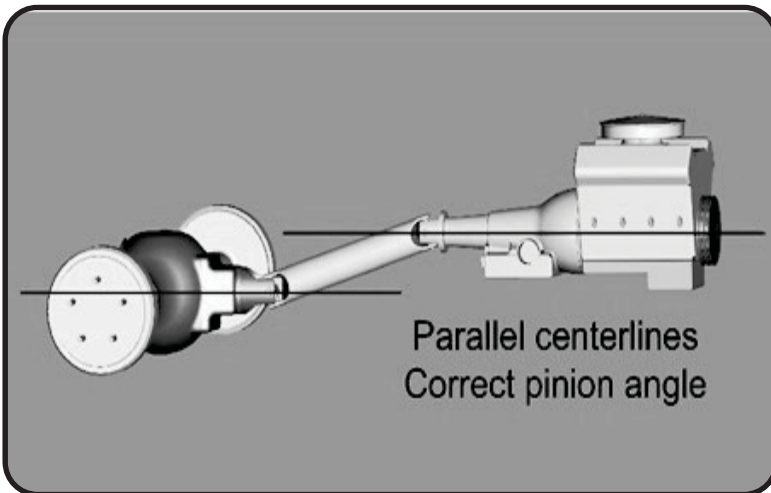
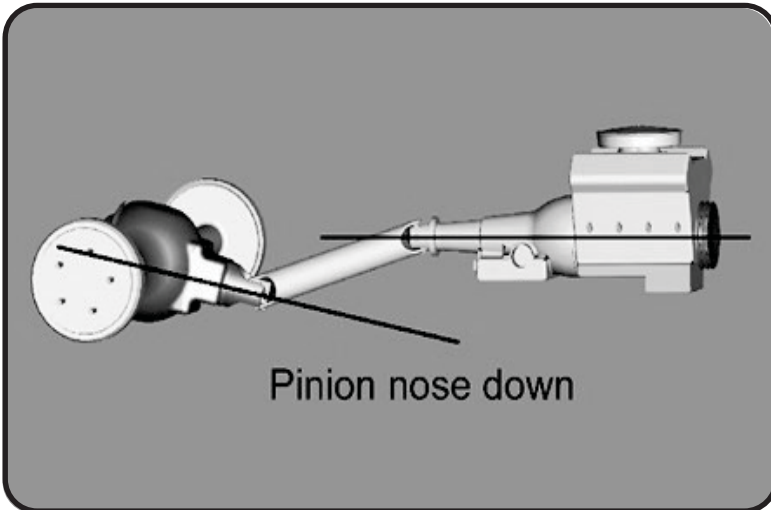



Upper Bar Tab Installation Jig

Upper Bar Installation Jig

- This jig has been supplied to aid in the installation of the upper 4 link bar. It can be temporarily used to properly align, locate and weld the tabs onto the axle. It will also ensure that the mounting bolts are parallel to the ground.
- Follow the diagram below to set the jig to the same length as the upper bar, use the 3/8" x 3/4" bolt and nuts to set the length.
- Position the axle at ride height. Center the axle left to right between the quarter panels. Set pinion angle.
- Bolt one end of the jig to the cradle using a 5/8" x 2 3/4" bolt.
- Using another 5/8" x 2 3/4" bolt, fasten the axle tabs to the other end. The tall tab goes to the outside of the car. The short tab goes to the inside of the car (some cars may need a tall tab on the inside). The tabs must be bolted to the outside of the jig.
- Swing the bar down letting the tabs rest onto the axle. Trim the brackets as necessary to minimize the gap to be welded.
- Check pinion angle, ride height and axle center. Tack-weld the tabs in place.
- Remove jig and install upper bar.
- Repeat this process for the other side.
- Recheck pinion angle, ride height and axle center. (Sound familiar?)
- After the tabs have been tack welded on both sides, remove the upper bars to avoid melting the rubber bushings. Let the axle drop down for better access to the tabs. Lay 1" welds on the inside and outside of the tabs. Skip around from one side to the other to avoid overheating the tube.

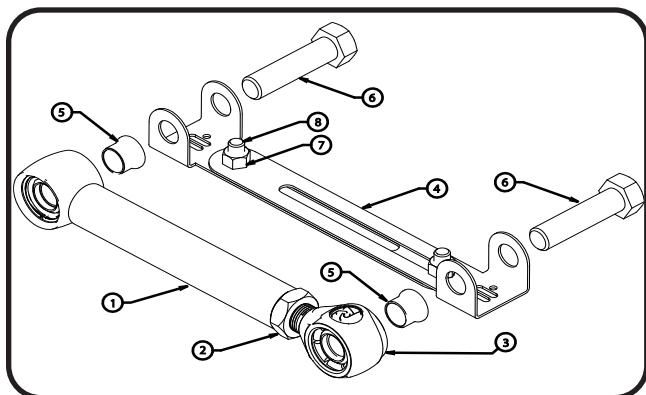

| Item# | Description |
|-------|---------------------|
| 1 | Upper Bar |
| 2 | 3/4"-16 Jam Nut |
| 3 | R-Joint End |
| 4 | Alignment Jig |
| 5 | Aluminum Spacer |
| 6 | 5/8" x 2 3/4" Bolt |
| 7 | 3/8"-16 Nut |
| 8 | 3/8"-16 x 3/4" Bolt |



Installing Axle Tabs

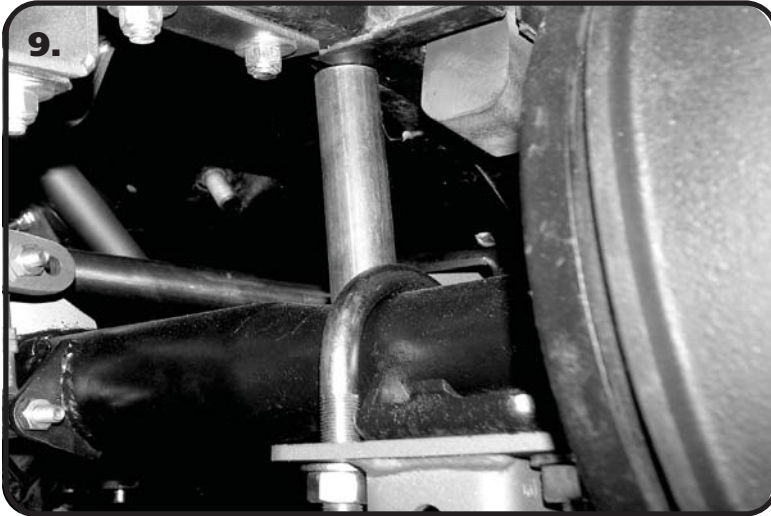

9. One helpful trick to maintain ride height when setting the pinion angle is to put a spacer between the axle and the frame. The spacer should be 4 1/2" tall. Set the pinion Angle and axle center. When measuring the axle center you can measure off of the frame rails. We also use a plum bob off the quarter panels to double check the axle center. Refer to Page 6 on Setting the Pinion Angle.

Note: You can tack weld the spacer in place after you get the Pinion Angle, and Axle Center set. This will ensure that nothing moves through the Upper Tab Installation.

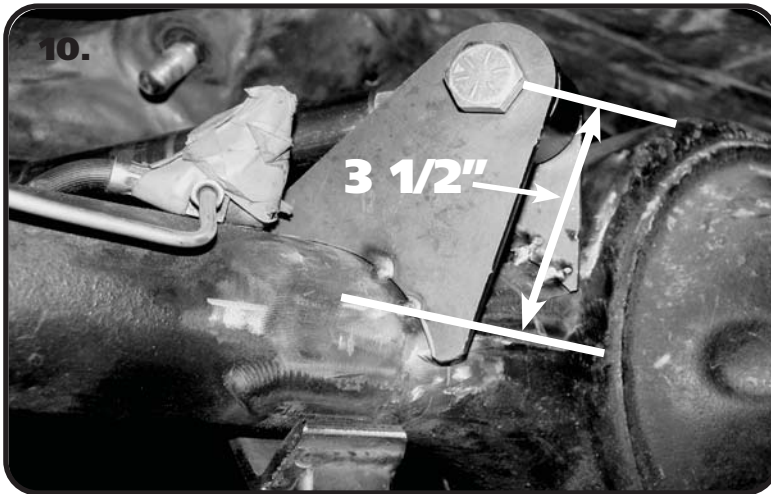

10. Refer to Page 7 and set the length of the Upper Bar Jig and install the Tabs on the Jig. Insert the Jig into the Cradle. Set the Upper Tabs on the Rearend. Due to different variations of the Rearend Housings, it may be necessary to modify the tabs for the best fit. The height you are wanting to achieve with the upper bar end is 3 1/2" from the axle center line. Modify the tabs so that the center of the bar bushing will be 3 1/2" from the center of the axle.



11. Once the bar end height is set, tack weld the tabs to the axle. Do this for the Driver and Passenger side bars. Insert the bars into the Cradle and Tabs to double check fitment. Recheck Axle Center and Pinion Angle. Once satisfied with fitment weld the Upper bar Tabs onto the Axle. Weld 1" at a time, skip around from one side to the other, and one tab to the other to avoid overheating the Axle Tube. When the tabs cool down, insert NARROW(70013334) spacers into each side of the R-Joints of the Upper Bar. Attach the upper bars using (1)5/8" x 2 3/4" Bolt, and (1) 5/8" Thin Nylok Nut.



Installing Shockwaves/Coilovers

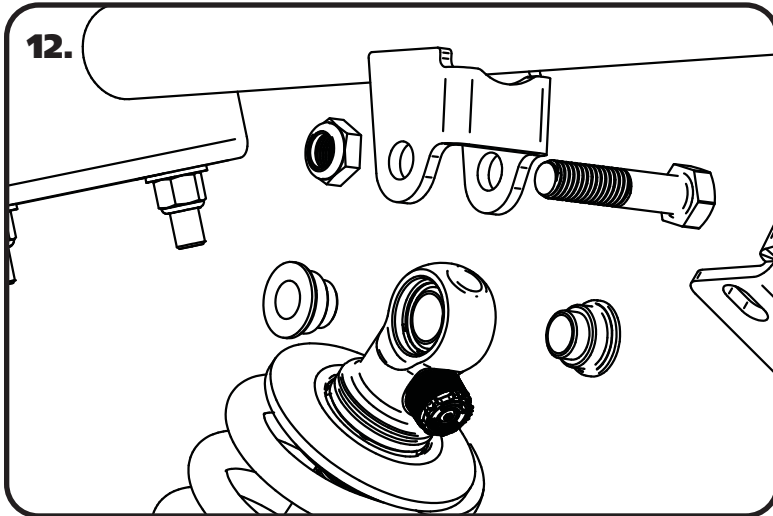

Remove the Spacer from between the Axle and Frame.

12. Install a 1/2" ID Spacer on each side of the upper Coilover/ShockWave. Slide the assembly into the upper crossmember from the bottom side. If your shock has an adjuster knob position it so that the knob points toward the center of the car. Line up the hole in the spacers with the hole in the upper shock bridge and insert 1/2" x 2 1/2" bolt and install 1/2" Nylok nut.

NOTE: BEFORE INSTALLING SHOCKWAVES
The correct pinion angle must be set first. Failure to do so could result in damage to the ShockWave by the bag rubbing the Lower Axle Mount.

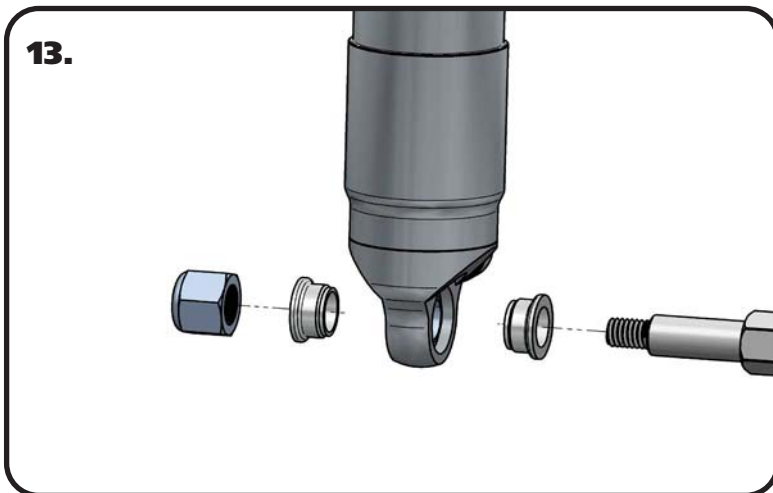

13. Install a 5/8" ID spacer(Small side towards shock body) onto the lower Shock Stud. Slide the bottom of the Shock onto the Stud. Install a second 5/8" ID Spacer onto the Stud(small side towards shock). You may need to jack the rearend up to Slide the Shock onto the Stud. Install the 7/16" Flat washer and 7/16" Nylok nut. Tighten the upper and lower shock bolts.

Note: If installing Shockwaves and you want to locate the air fitting in a different location, the air spring assembly can be rotated on the shock by grabbing the shock and air spring assembly by hand and spinning the shock in the air spring assembly.

The designed ride height of the CoilOver/Shockwave is 14 1/2" center to center.